

- ▲ 6 Models to choose from, allowing you to adapt a bracket to your application.
- ▲ 3 Adjustable models, giving you greater flexibility.
- ▲ All E-Z Fender Mount brackets have the time tested single mounting bolt. Very Quick- Very Easy!

- ▲ 3 Straight models available with rubber spacers, which provide 1" clearance between the fender and bracket, allowing dirt and gravel to pass through... makes cleaning easier.
- ▲ All hardware is supplied with each bracket for mounting.

- ▲ Fender to bracket mounting hardware is made from stainless steel.
- ▲ Mounting instructions included with each bracket for installation.
- ▲ Stocked in all Merritt warehouse locations.

E-Z MOUNT FENDER BRACKET



E-Z MOUNT FENDER BRACKET ORDER INFORMATION

ADJUSTABLE FENDER BRACKETS

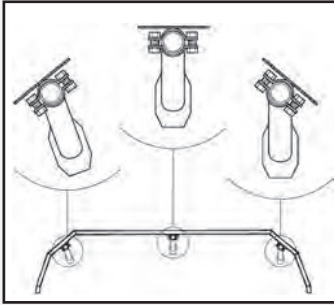

All three E - Z fender brackets are adjustable in length from 27" to 30".

Stainless steel cap screw mounting plate bolts are included.

Installation Notes:

- ▲ Backing plate is designed to be used as a template to drill holes in fender.
- ▲ When installing the 3/8" x 2 1/4" bolts, it is recommended that the bolts are not over tightened, 10inch lbs. torque.
- ▲ It is necessary to bend TAB Lock-washers downward into the bolt to prevent unwinding.
- ▲ Torque 5/8" nuts to 150 ft/lbs.

E - Z Fender Bracket - Black - 4" Model

Part #

567

Weight: 12 lbs

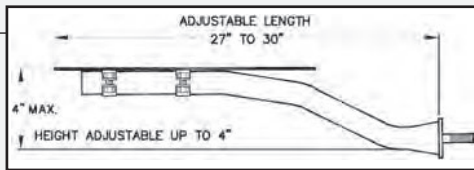

E - Z Fender Bracket - Black - 8" Model

Part #

568

Weight: 12 lbs

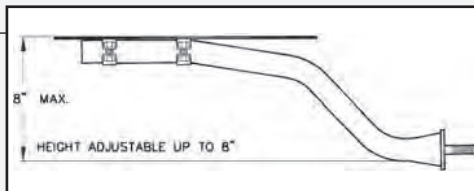

E - Z Fender Bracket - Black - 10" Model

Part #

569

Weight: 12 lbs

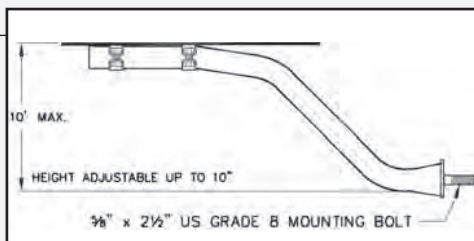

STRAIGHT FENDER BRACKETS

This is a Universal Bracket-designed to mount outside any fender.

Features:

- ▲ Mounts solidly to frame with single grade 8 bolt
- ▲ 574 Mounts to the existing stub shaft or the 573 post, making those hard installations easier
- ▲ Bracket Mounts 1" off Fender so rocks and gravel can pass through

Mounting Post - Zinc Plated

Part #

573-2 Pair

Weight: 5 lbs

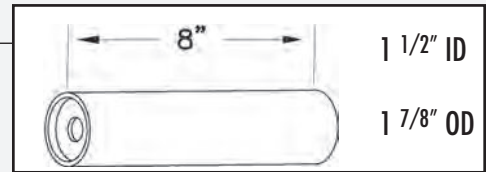

Post Mount Bracket - Chrome

Part #

574

Weight: 8 lbs

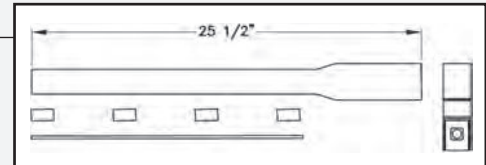

Straight Bracket

Part #

575 Black

Weight: 12 lbs

576 Chrome

Weight: 12 lbs

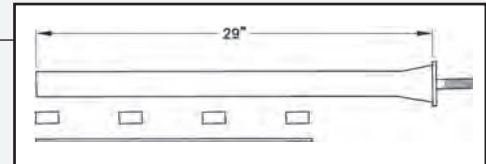

Frame Spacer

Part #

1560 Black

Weight: 1 lbs

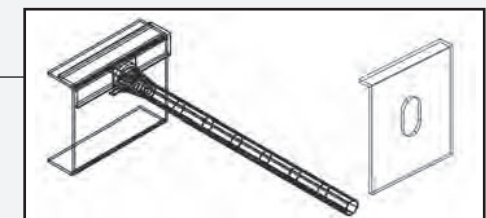

- ▲ If your EZ-Mount bracket, mounted in the center and on the fifth wheel plate does not have full contact, the 1560 will allow a fix for this
- ▲ Just mount with the "leg" below (see the drawing) the fifth wheel plate and then mount the bracket through the plate making a 100% contact mount for the bracket.
- ▲ The 1560 package includes 2 plates, one for each side and instructions on how to use.

Models and/or Specifications Subject to Change Without Notice.

F.O.B. - Fort Lupton CO, Sacramento CA, Salt Lake City UT, Dallas TX, Houston TX, Kansas City MO, Minneapolis MN, Atlanta GA, Pittsburgh PA, Calgary AB (CN), Toronto ON (CN)

Copyright © 2017 Merritt Aluminum Products Company. All Rights Reserved.

ALUMINUM PRODUCTS
MERRITT
 1-800-525-0107

Follow us on Facebook!! 

- ▲ Turn your 574 straight bracket into an adjustable mount, for those installations where nothing seems to work.
- ▲ Allows the installer to adjust the height of a straight bracket (like EZ Mount bracket).
- ▲ Delivers a full 3" sweep to allow you to find the best mounting position.
- ▲ Fits the new style air ride suspension systems. Bolts directly to the suspension hanger, eliminating hole drilling in the frame.
- ▲ Made from hardened billet steel for long life.
- ▲ Shipped in pairs, stocked in 12 Merritt warehouse locations.
- ▲ To be used with part numbers 574 Post Mount Bracket and 573 Post.

E-Z FENDER MOUNTING SYSTEMS

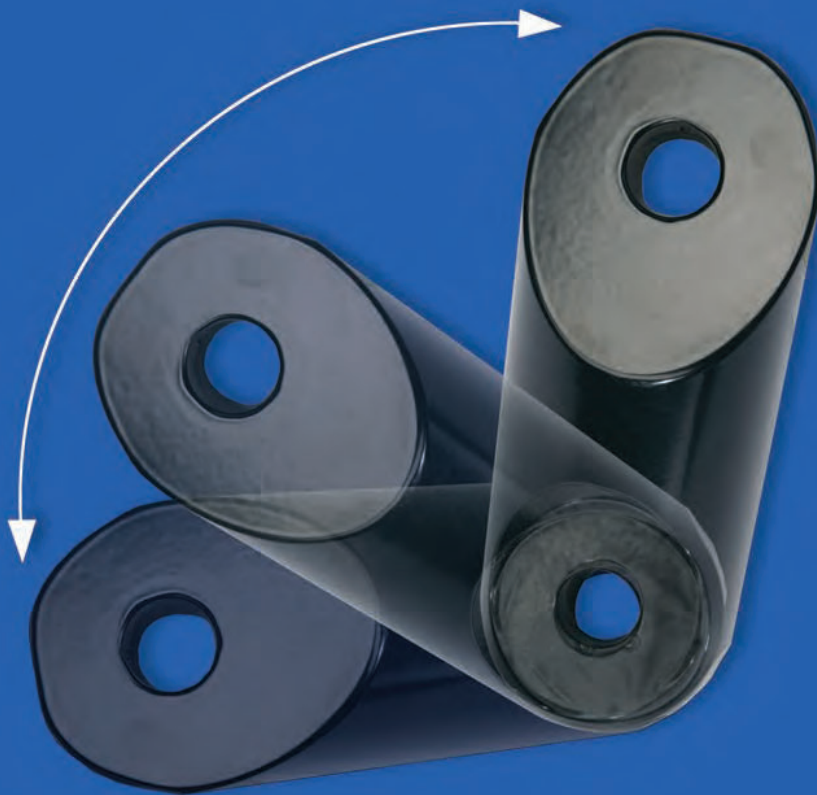

Post Mount Bracket - Side View

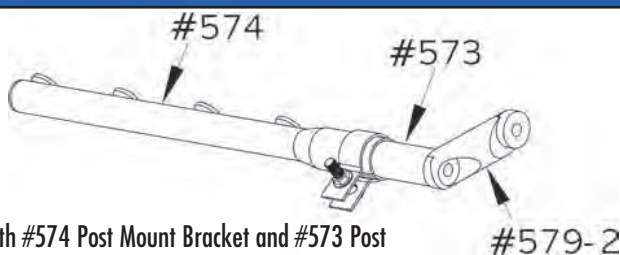

#573 Shown with #574 Post Mount Bracket and #573 Post

Weight per unit 3 lbs
Shipping Weight 7 lbs
(Shipped as a set - 2 per box)

3" Offset Adapter Part Number 579-2 23A

- ▲ 2 Models to choose from, allowing you to adapt a bracket to your application.
- ▲ Proven in one of the toughest environments in the world.
- ▲ Ideal for heavy-duty trucks, thriving in harsh environments.
- ▲ Normal hand tools used for installation

- ▲ Stocked in most Merritt warehouse locations.
- ▲ Each Heavy Duty Fender Mounting kit will mount two quarter fenders or one single axle fender. Can be used to mount a full fender using an E-Z Mount adjustable center bracket.
- ▲ Light, very strong and highly durable.

- ▲ Heavy duty truck fender mounting kits include:

2 off-set tube mounts (steel tube and cast aluminum boss)

4 cast aluminum mounting brackets that securely fasten onto the tube and the fender.

E-Z HD FENDER MOUNTING KIT



OFFSET PIPE FENDER BRACKETS

Offset Pipe Fender Bracket is designed to mount outside any fender.

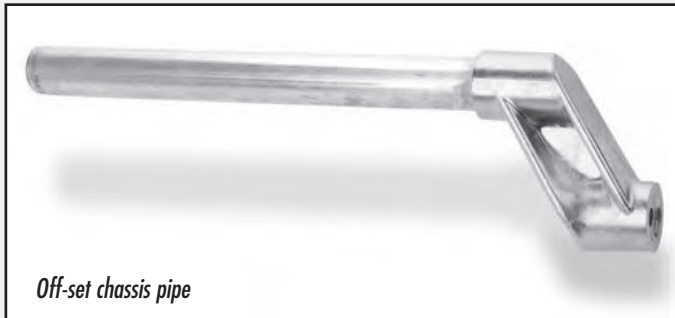

Off-set chassis pipe

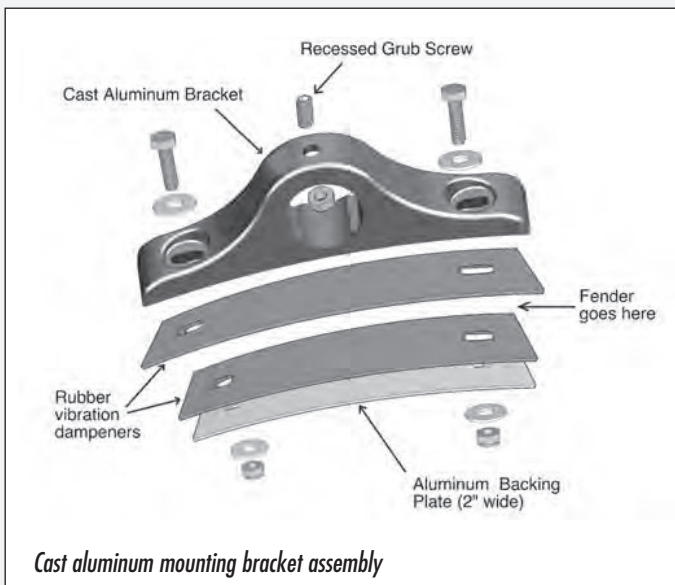

Cast aluminum mounting bracket assembly

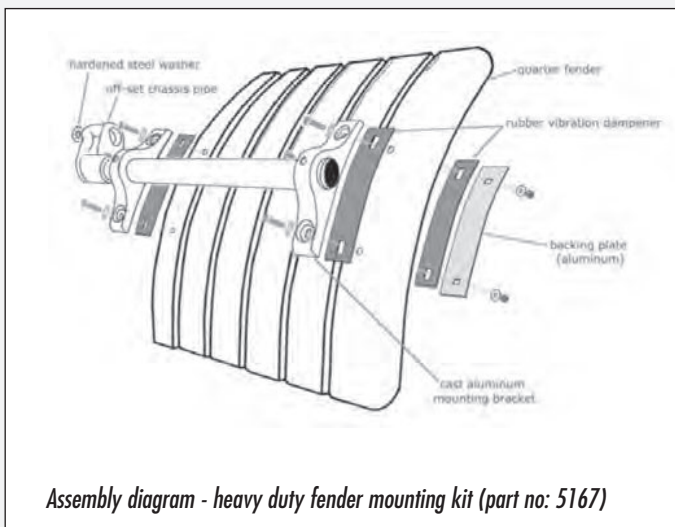

Assembly diagram - heavy duty fender mounting kit (part no: 5167)

Features:

Off-set chassis pipe mounts solidly to frame with single grade 8 bolt

Installation Notes:

- ▲ It is necessary to bend TAB Lock-washers downward into the bolt to prevent unwinding.
- ▲ Torque 5/8 Nyloc nuts to 150 ft/lbs.

Features:

Cast Aluminum Brackets mount to the fender as shown, secure the Grub Screw to the pipe shaft, making those hard installations a breeze.

Installation Notes:

- ▲ Mounting bracket backing plate can be used as a template to drill holes in fender.
- ▲ When installing the 3/8" x 2 1/4" bolts, it is recommended that the bolts are not over tightened, 10inch lbs. torque.
- ▲ Secure mounting bracket to chassis pipe/tube using "Grub Screw" and 3/8" conelock nut.

E-Z HD FENDER MOUNTING KITS

Order #	Description	Weight Lbs.
5167-2	Two mounting tubes, Four cast, curved fender brackets and mounting hardware	24
5168-2	Two mounting tubes, Four cast, straight fender brackets and mounting hardware	24

Models and/or Specifications Subject to Change Without Notice.

F.O.B. - Fort Lupton CO, Sacramento CA, Salt Lake City UT, Dallas TX, Houston TX, Kansas City MO, Minneapolis MN, Atlanta GA, Pittsburgh PA, Calgary AB (CN), Toronto ON (CN)